

HC系列反击式破碎机 HC Series Impact Crusher

HC系列反击式破碎机是在吸收国外先进技术,并结合国内实际情况进行优化设计,整体结构简单实用且不失合理,更加人性化,同时腔型更大、更优,在同条件下,提高了生产效率。

HC系列反击式破碎机广泛用于破碎各种软、中硬矿石,能够在初级破碎和二级破碎中进行粗碎、中碎、细碎。主要用于矿山、建筑、化工、水泥、冶金等行业。

HCP反击破主要用于粗碎,具有进料粒度大,通过量高等特点。HCS反击破主要用于二级破碎,具有产品粒度小,粒形好等特点。

HC Series Impact Crusher is built on advanced technology with a combination of domestic applications. More human-oriented with simple design and reasonable structure, bigger and better cavity, higher capacity.

HC Series Impact Crusher can crush kinds of soft and medium-hard ore, for coarse, medium and fine crushing, in primary and secondary crushing process. The series can be widely used in mining, construction, chemistry, cement.

HCP series impact crusher is mainly used in primary crushing and it has features of big input size ad high capacity and etc. HCS impact crusher is mainly used in secondary crushing and it has features of small product size and good shape and etc.



HC系列反击破具体特点如下:

- 1、优质的板材和耐磨件,减少了磨损,提高了各种工况下生产效率,先进的加工设备和工艺,是性能卓越的设备的基础。
- 2、产品通用性强,两腔破碎设备在不更换其他零部件的基础上,增加研磨架(A),即可变为三腔破碎设备,减少用户二次投资。
- 3、重型转子,进行有限元受力分析,优化设计,结构更加合理,转动惯量更大,获得更大的破碎比,破碎能力、耐磨性更强。
- 4、转子焊接加工后,装配前需做静、动平衡试验,使转子运转更加平稳,使用时间更长。
- 5、主轴采用优质锻件进行精加工,同时全轴无键设计,采用了国际先进的胀套涨紧连接方式,使设备运转更可靠,后期维护更加简便。
- 6、独特的板锤锁紧装置,紧固力矩更大、更安全,板锤更换更加简单、方便、快捷。
- 7、衬板标准化设计,互换性强,减少用户备件种类和库存,且更换更加容易。
- 8、简单实用的锁紧装置,将反击破壳体一与壳体二紧紧的锁在一起。此种装置操作简单,方便,节约锁紧时间。
- 9、独特的液压装置设计,既能方便用户轻松打开机架,更换零部件,又能对反击架排料口调节。
- 10、反击架及研磨架调整结构简单,易操作,不易损坏,同时维修方便,成本低廉。

Features and Benefits for HC Series Impact Crusher:

- 1 High qualified raw material, less wear, high productivity under any circumstances. Top manufacturing process is the basis for extraordinary machine.
- 2 Strong product commonality can reduce cost. Two-cavity impact crusher can become three-cavity machine by adding grinding racks (A), and no need to change other parts.
- 3 Heavy type rotor, finite element endurance analysis, optimized design, reasonable structure and enhancing moment of inertia lead to bigger crushing ratio and better abrasion resistance.
- 4 Static and dynamic balancing test for the welding rotor should be done before assembling. To make sure the rotor have a smoothly running and long working life.
- 5 Main shaft is finished by quality forging, adopts keyless design and world advanced cover tightening connection to ensure the reliable working and make the maintenance easier.
- 6 Unique locking device for hammers makes the tightening moment of force more safe and bigger. And the replacement of hammers can be more simple and convenient.
- 7 Standard design for liners increases the interchangeability, decreases the repertory and variety of liners.
- 8 Simple but practical locking device locks the shell 1 and shell 2 together. This device has an easy operation and saves locking time.
- 9 Unique hydraulic device design is convenient for opening the fame racks to replace wear parts and adjust the discharge size.
- 10 Simple adjustment of impact rack and grinding rack, not easy to damage, convenient maintenance and low cost.

HC系列反击式破碎机 HC Series Impact Crusher

结构图 Structure Drawing

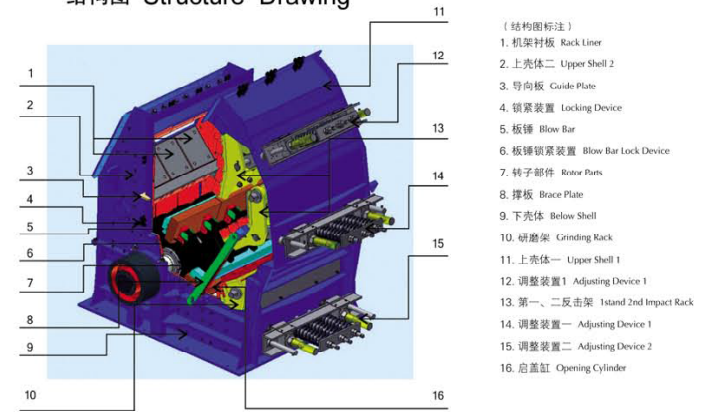

(结构图标注)

1. 机架衬板 Rack Liner
2. 上壳体 Upper Shell 2
3. 导向板 Guide-Plate
4. 锁紧装置 Locking Device
5. 板锤 Blow Bar
6. 板锤锁紧装置 Blow Bar Lock Device
7. 转子部件 Rotor Parts
8. 撑板 Brace Plate
9. 下壳体 Below Shell
10. 研磨架 Grinding Rack
11. 上壳体一 Upper Shell 1
12. 调整装置1 Adjusting Device 1
13. 第一、二反击架 1st and 2nd Impact Rack
14. 调整装置一 Adjusting Device 1
15. 调整装置二 Adjusting Device 2
16. 启盖缸 Opening Cylinder

HCP技术参数 HCP Technical Data

型号 Model	最大进料边长 Max Feed Edge(mm)	通过量 Capacity(t/h)	电机功率 Motor Power(kw)	重量(不含电机) Weight (Excluding Motor)(t)	
				带研磨腔 with grinding cavity	不带研磨腔 without grinding cavity
HCP239(A)	500	90-160	110-132	14.696	13.596
HCP255(A)	500	100-200	132-160	17.43	16.12
HCP359(A)	600	180-300	200-250	25.64	24.2
HCP459(A)	650	220-450	250-315	27.046	25.438
HCP579(A)	700	250-550	400-440	35.3	33.3
HCP679(A)	800	300-600	440-560	52.6	48.3
HCP779(A)	1000	500-850	630	84.1	78.9

HCS技术参数 HCS Technical Data

型号 Model	最大进料边长 Max Feed edge(mm)	通过量 Capacity(t/h)	电机功率 Motor Power(kw)	重量(不含电机) Weight (Excluding Motor)(t)	
				带研磨腔 with grinding cavity	不带研磨腔 without grinding cavity
HCS128(A)	250	40-70	55-75	11.8	10.98
HCS139(A)	300	70-100	75-90	14.4	13.47
HCS239(A)	350	100-180	132-160	14.696	13.596
HCS255(A)	350	150-290	160-200	17.43	16.12
HCS359(A)	400	200-300	250-315	25.64	24.2
HCS459(A)	450	250-450	315-400	27.046	25.438
HCS579(A)	500	280-550	400-440	35.3	33.3
HCS679(A)	600	300-600	440-560	52.6	48.3
HCS779(A)	700	500-850	630	84.1	78.9